

# TOUCH HD

Quick Start Guide

---

## **Please Read Before Proceeding**

**THE BATTERY IS NOT CHARGED WHEN YOU TAKE IT OUT OF THE BOX.**

**DO NOT REMOVE THE BATTERY PACK WHEN THE DEVICE IS CHARGING.**

**YOUR WARRANTY IS INVALIDATED IF YOU OPEN OR TAMPER WITH THE DEVICE'S OUTER CASING.**

## **PRIVACY RESTRICTIONS**

Some countries require full disclosure of recorded telephone conversations, and stipulate that you must inform the person with whom you are speaking that the conversation is being recorded. Always obey the relevant laws and regulations of your country when using the recording feature of your PDA Phone.

## **Disclaimers**

THE WEATHER INFORMATION, STOCK DATA, DATA, AND DOCUMENTATION ARE PROVIDED "AS IS" AND WITHOUT WARRANTY OR TECHNICAL SUPPORT OF ANY KIND FROM HTC. TO THE MAXIMUM EXTENT PERMITTED BY APPLICABLE LAW, HTC AND ITS AFFILIATES expressly disclaim any and all representations and warranties, express or implied, arising by law or otherwise, regarding the Weather Information, Stock Data, Data, Documentation, or any other Products and services, including without limitation any express or implied warranty of merchantability, express or implied warranty of fitness for a particular purpose, non-infringement, quality, accuracy, completeness, effectiveness, reliability, usefulness, that the Weather Information, Stock Data, Data and/or Documentation will be error-free, or implied warranties arising from course of dealing or course of performance.

Without limiting the foregoing, it is further understood that HTC and its Providers are not responsible for Your use or misuse of the Weather Information, Stock Data, Data and/or Documentation or the results from such use. HTC and its Providers

---

---

make no express or implied warranties, guarantees or affirmations that weather information will occur or has occurred as the reports, forecasts, data, or information state, represent or depict and it shall have no responsibility or liability whatsoever to any person or entity, parties and non-parties alike, for any inconsistency, inaccuracy, or omission for weather or events predicted or depicted, reported, occurring or occurred. WITHOUT LIMITING THE GENERALITY OF THE FOREGOING, YOU ACKNOWLEDGE THAT THE WEATHER INFORMATION, STOCK DATA, DATA AND/OR DOCUMENTATION MAY INCLUDE INACCURACIES AND YOU WILL USE COMMON SENSE AND FOLLOW STANDARD SAFETY PRECAUTIONS IN CONNECTION WITH THE USE OF THE WEATHER INFORMATION, STOCK DATA, DATA OR DOCUMENTATION.

## **Limitation of Damages**

TO THE MAXIMUM EXTENT PERMITTED BY APPLICABLE LAW, IN NO EVENT SHALL HTC OR ITS PROVIDERS BE LIABLE TO USER OR ANY THIRD PARTY FOR ANY INDIRECT, SPECIAL, CONSEQUENTIAL, INCIDENTAL OR PUNITIVE DAMAGES OF ANY KIND, IN CONTRACT OR TORT, INCLUDING, BUT NOT LIMITED TO, INJURY, LOSS OF REVENUE, LOSS OF GOODWILL, LOSS OF BUSINESS OPPORTUNITY, LOSS OF DATA, AND/OR LOSS OF PROFITS ARISING OUT OF, OR RELATED TO, IN ANY MANNER, OR THE DELIVERY, PERFORMANCE OR NONPERFORMANCE OF OBLIGATIONS, OR USE OF THE WEATHER INFORMATION, STOCK DATA, DATA OR DOCUMENTATION HEREUNDER REGARDLESS OF THE FORESEEABILITY THEREOF.

---

# Contents

1. Welcome to the HTC Touch HD™ Quick Start Guide .....	6
2. Inside the Box .....	6
3. Getting to Know the HTC Touch HD™ .....	7
4. Installing the SIM Card, Battery, and Storage Card .....	8
5. Charging the Battery .....	10
6. Starting Up.....	10
7. The TouchFLO™ 3D Home Screen .....	11
8. Making Your First Call.....	13
9. Making a Video Call .....	14
10. Entering Information.....	15
11. Basic Settings .....	16
12. Adding Favorite Contacts.....	18
13. Sending a Text Message.....	19
14. Sending an MMS Message.....	20
15. Using Wi-Fi .....	20
16. Setting Up an Internet E-mail Account.....	21
17. Mobile Internet .....	22

---

18. Bluetooth.....	23
19. Keeping Track of Appointments .....	25
20. Keeping Track of Things to Do .....	25
21. Taking Photos and Shooting Videos.....	26
22. Viewing Photo and Videos .....	27
23. When Connecting Your Device to a Computer .....	28
24. Synchronizing Your Device with Your Computer .....	29
25. Copying Files to Your Device .....	30
26. Synchronizing Music Files .....	30
27. Listening to Music on Your Device .....	31
28. Resetting Your Device .....	32

---

## 1. Welcome to the HTC Touch HD™ Quick Start Guide

Congratulations on your purchase of the HTC Touch HD.

This **Quick Start Guide** will help you get started with your Windows Mobile® 6.1 Professional powered Touch Phone. We've arranged this Quick Start Guide in a way that it starts from when you open the box and then it walks you through the features we feel that you want to know or use right away when you turn on your device for the first time.

For a more complete guide in using your device, please refer to the **User Manual PDF** that we have included in the **Getting Started CD** that came with the device. The Getting Started CD also includes some programs that you can install on your device.

## 2. Inside the Box

You should find the following items inside the box.

- HTC Touch HD device
  - Battery
  - AC adapter
  - Wired stereo headset
  - USB sync cable
  - Pouch
  - Screen protector
  - 8GB microSD™ card
  - Quick Start Guide
  - Getting Started and Application Discs
  - Extra stylus
-

### 3. Getting to Know the HTC Touch HD™

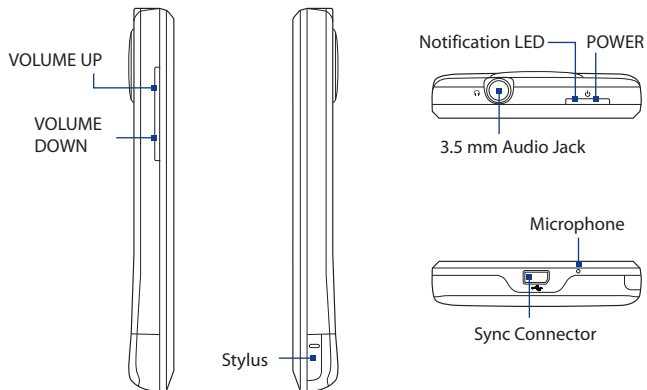
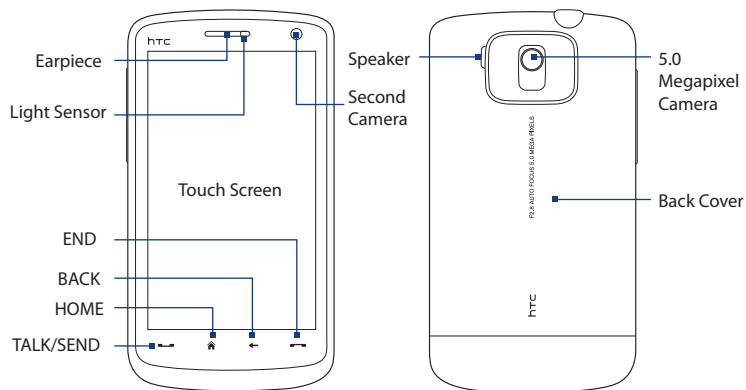

## 4. Installing the SIM Card, Battery, and Storage Card

Make sure your device is turned off before installing the SIM card, battery, and storage card. You also need to remove the back cover before you can install these components.

### To remove the back cover

1. Make sure your device is turned off.
2. Firmly hold the device with both hands and the front panel facing down.
3. Push the lower part of the back cover up with your thumbs until it disengages from the device and then slide it up to remove.

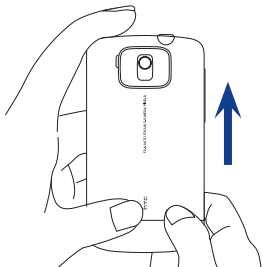

### To install the SIM card

1. Make sure your device is turned off.
2. Locate the SIM card slot, then insert the SIM card with its gold contacts facing down and its cut-off corner facing out the card slot.
3. Slide the SIM card completely into the slot.

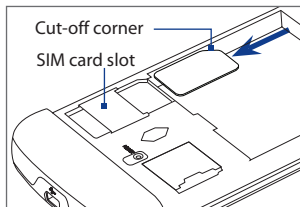

### To install the battery

1. Align the battery's exposed copper contacts with the battery connectors inside the battery compartment.
2. Insert the contacts side of the battery first and then gently push the battery into place.
3. Replace the back cover.

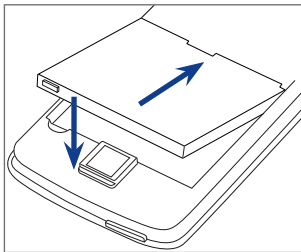

### To install a microSD™ card

Locate the storage card slot, then insert the microSD card into the slot with its gold contacts facing down until it clicks into place.

**Note** To remove the microSD card, press it to eject it from the slot.

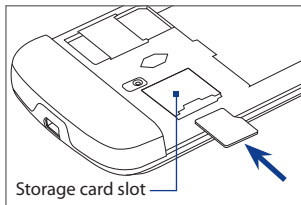

For information on how to remove or replace these components on your device, refer to the User Manual PDF on the Getting Started disc.

## 5. Charging the Battery

New batteries are shipped partially charged. Before you start using your device, it is recommended that you install and charge the battery.

### To charge the battery

1. Connect the USB connector of the AC adapter to the sync connector at the bottom of your device.
2. Plug in the AC adapter to an electrical outlet to start charging the battery. The battery is fully charged after about **3 hours** of charging.

## 6. Starting Up

After installing the battery and charging the battery, you can now power on and start using your device.

### To turn on the power

1. Press the POWER button.
2. A Quick Start Wizard guides you through the calibration of the screen and the setup of date and time, and password. Follow the onscreen instructions to finish the Quick Start Wizard. After the Quick Start Wizard finishes, the device installs customization settings, then restarts.

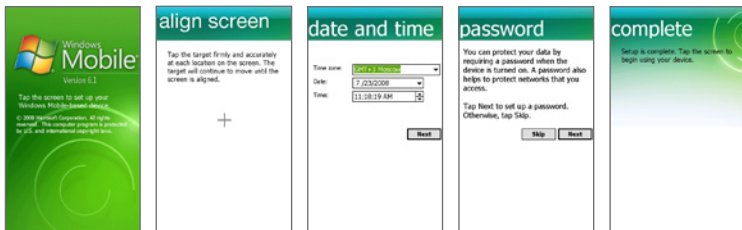

## Auto configure data connection settings

After the device restarts, you will be asked if you want to automatically configure your device's data connections.

Follow the onscreen instructions to go through the configuration process so that you do not need to enter the settings for 3G/GPRS, MMS, and WAP manually. After the configuration is completed, tap **Restart**.



## 7. The TouchFLO™ 3D Home Screen

Your device's main screen is the TouchFLO™ 3D Home screen which allows finger-touch access to the most important functions such as favorite contacts, text messages, e-mail, Internet, and more.

The following are some of the tabs you will find on the TouchFLO 3D Home screen:



Home

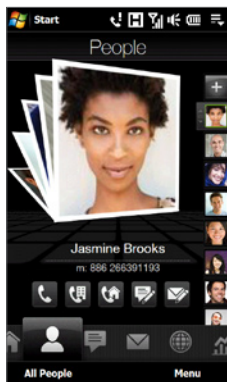

People

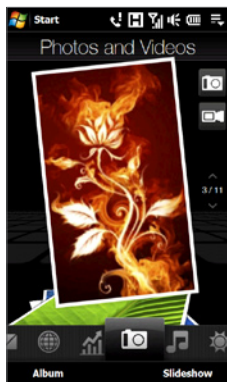

Photos and Videos

### To switch between the tabs of the Home screen

Do one of the following:

- Touch or tap the desired tab on the Home screen.
- Swipe left across the screen to move to the next tab, and swipe right across the screen to move to the previous tab.
- Press and hold your finger on the active tab, then slide your finger right or left over the tabs.

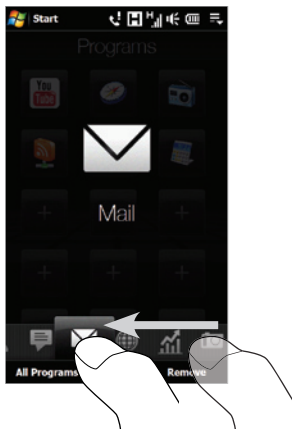



**Note** Apply some pressure when pressing and holding on the active tab to be able to slide over the tabs.

The succeeding sections in this Quick Start Guide will show you how to use some of the Home screen tabs. For complete information about using TouchFLO 3D, refer to the User Manual PDF on the Getting Started disc.

---

## 8. Making Your First Call

1. On the Home screen, tap **Phone**.
2. Tap the keys on the keypad to enter the phone number.

**Tip** If you tapped a wrong number, tap  to erase each subsequent digit of a number. To erase the entire number, tap and hold .

3. Tap **Talk** to place the call.

**Tip** When in a call, use the VOLUME UP/DOWN buttons on the side of the device to adjust the phone volume.

4. When a call is in progress, tap **End Call** or press END to hang up.

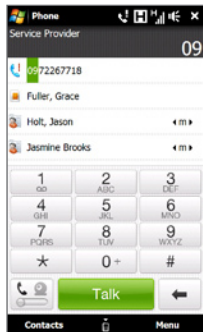

### Accept or reject an incoming call

When you receive a phone call, the Incoming Voice Call screen will appear, allowing you to either answer or ignore the call.

#### To answer a call

Press the TALK/SEND button.

#### To reject an incoming call

Press the END button.

#### To mute the ringing sound

To mute the ring without rejecting the call, tap **Mute Ring** at the bottom right side of the Incoming Voice Call screen.

#### To reject a call and send a text message

When **Reject call with text message** is enabled, tap **Send Text** when the phone rings to reject the call and send the text message to the caller.

**Note** For information on how to enable the **Reject call with text message** option, refer to the User Manual PDF on the Getting Started disc.

## 9. Making a Video Call

Do one of the following:

- On the Phone keypad, tap the phone number to call, then tap **Menu > Video Call** to start a video call.
- On the Phone screen, tap the phone number to call, tap , then tap the **Video Call** button.
- From Contacts, tap and hold the desired contact, and tap **Video Call**.
- From Call History, tap and hold the desired phone number or contact, and tap **Video Call**.

**Note** The other party's image will appear on the screen about 3 to 5 seconds after a connection is established, depending on the signal strength. The streaming images quality may also be influenced by the signal.

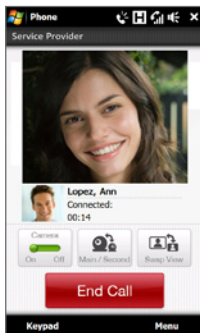

### Change the video call settings

On the Phone screen, or on the screen of the ongoing video call, tap **Menu > Video Call Options** and set the general video call and services options.

**Note** While on a video call, you can change certain settings such as the size of the image, brightness of the video image, the camera to use, and more. Refer to the User Manual for details.



## 10. Entering Information

When you need to enter text, choose one of the available onscreen input methods. Here are some examples of onscreen input methods.



Full QWERTY

Touch the Navigation Control keys at the bottom of the keyboard for directional control.



Compact QWERTY

To enter text, simply tap the keys on the onscreen keyboard. Depending on the keyboard layout selected, you may need to tap the same key more than once to select the desired character.

**Tip** When using T9 mode, tap the **SPACE** key to select the first word in the predicted word list.

For more information about using the different input methods, refer to the “Entering Text” chapter in the User Manual PDF.

## 11. Basic Settings

Customize your device settings to suit your personal needs.

### Ring tone

1. Press TALK/SEND to open the Phone screen and then tap **Menu > Options**.
2. In the Ring tone list, select the desired ring tone and then tap **OK**.

### Alarm clock

1. On the Home screen, select the Home tab and then tap the time display.
2. Tap the **Alarms** tab.
3. Select an alarm check box to enable it. Edit the **Description** of an enabled alarm by tapping the default description and changing the text.
4. Tap the days you want the alarm to sound.
5. Tap the time to set the time you want the alarm to sound.

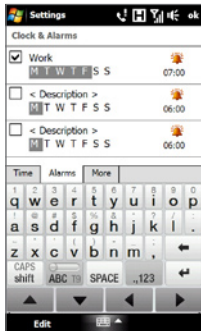

### Phone profile

A profile is a preset that determines how your device will alert you when there are incoming phone calls. To select a profile:

1. On the Home screen, slide to the **Settings** tab and then tap **Sound**.
2. Choose one of the following: **Normal**, **Vibrate**, **Silent**, or **Automatic**.

- Notes**
- **Automatic** sets your device to vibrate only when you receive phone calls during scheduled appointments in your Calendar.
  - If you have set an alarm and you select the **Vibrate** or **Silent** profile, you will not hear the alarm sound when the alarm goes off. To enable the alarm sound, make sure you turn on the **Alarm Sound** option on the Sound Profiles screen.

## Wallpaper

You can change the background image of the **Home** tab.

1. On the Home screen, slide to the **Settings** tab and then tap **Wallpaper**.
2. On the Select a Picture screen, navigate to the folder where the image you want to use is located. When you have found the desired image, tap the image to set it as the Home tab wallpaper.

## Device lock

Enabling device lock requires you to enter a password to unlock your device after it has been left idle for a set period of time.

1. On the Home screen, slide to the **Settings** tab and then tap **All Settings**.
2. On the Personal tab, tap **Lock**.
3. Select the **Prompt if device unused for** check box and choose the time to elapse before your device requires password entry.
4. Select the **Password** type.
5. Enter and confirm the password and then tap **OK**.

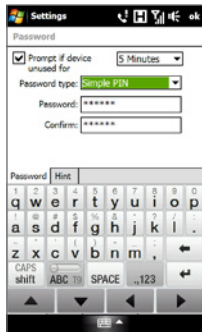

## SIM card PIN

Enabling the SIM card PIN requires you to enter a PIN number first before you can use the phone features of the device.

1. On the Home screen, slide to the **Settings** tab and then tap **All Settings**.
2. On the **Personal** tab, tap **Phone** > **PIN/PIN2** tab.
3. Select the **Require PIN when phone is used** check box.
4. Enter your PIN number and then tap **OK**.

## **Backlight and battery saving settings**

Conserve battery power by adjusting backlight and battery saving settings.

1. On the Home screen, slide to the **Settings** tab and then tap **All Settings**.
2. On the **System** tab, tap **Power**.
3. On the **Backlight** tab, clear the **Auto adjust backlight** check box and then adjust the brightness for battery power and for AC power by dragging the battery power and external power sliders.
4. On the **Advanced** tab, set when you want the backlight and device screen to turn off when using battery and external power. Tap **OK**.

## **12. Adding Favorite Contacts**

On the Home screen's **People** tab, you can add up to 15 favorite contacts. This allows you to quickly make calls, send text messages, and send e-mails to contacts who you most frequently communicate with.

### **To add contacts to your device**

Before you can add favorite contacts to the Home screen's People tab, you need to have contacts already stored in your your device's contacts list. Follow the steps below to add them first to your device.

1. Tap **Start > Contacts**.
2. Tap **New > Outlook Contact**.
3. Enter the contact information and then tap **OK**.

**Tip** If you have contacts stored on your SIM card and you want to add them as your favorite contacts, copy them first to your device. Tap **Start > Programs > SIM Manager**, tap **Menu > Select All**, and then tap **Menu > Save to Contacts**. (Copying SIM contacts to your device results in duplicate contacts when you view them on the Contacts screen.)

---

### To add favorite contacts to the People tab

1. On the Home screen, slide to the **People** tab.
2. Touch the small or big **Plus** icon, or touch **Add Favorite**.
3. On the Select a Contact screen, touch the name of the desired contact.
4. Select a phone number or e-mail address to associate to your favorite contact.

**Note** If there is no picture assigned to the contact, the next screen allows you to select or take a picture of the contact.

### To place a call or send a message to a favorite contact

1. On the Home screen, slide to the **People** tab.
2. Swipe your finger up or down the screen to scroll through the favorite contacts.
3. Touch an icon below the contact name to call or to compose and send a text or an e-mail message to the contact.

**Note** The icons shown will depend on available contact information. For example, (📞) will be shown if the contact's home phone is specified.



## 13. Sending a Text Message

Easily create and send SMS text messages from your device.

1. On the Home screen, slide to the **Messages** tab and tap .
2. In the **To** field, enter the mobile phone number of the person you want to send the message to.

**Tip** You can also tap **To** to select a contact from your contacts list.

3. Compose your message and then tap **Send**.

## 14. Sending an MMS Message

Create and send multimedia messages that contain pictures, videos, and audio clips.

1. On the Home screen, slide to the **Messages** tab and tap **All Messages**.
2. Tap **Menu > New > MMS** and then tap **Custom**.
3. Enter the recipient's mobile number or e-mail address in the **To** field and enter the **Subject** line.
4. Fill in the MMS message slide by tapping **Insert picture/video**, **Insert text here**, and **Insert audio**.
5. Tap **Send**.

## 15. Using Wi-Fi

You can use Wi-Fi to connect your device to the Internet if you have access to a wireless network.

### To connect to an open Wi-Fi network

1. On the Home screen, slide to the **Settings** tab and then tap **Communications**.
2. On the Comm Manager screen, tap **Wi-Fi** to turn Wi-Fi on.
3. The network names of the detected wireless networks are then displayed. Select an open (unsecured) wireless network and then tap **OK**.



To learn how to connect to a secured network, refer to the “Internet” chapter in the User Manual PDF.

## 16. Setting Up an Internet E-mail Account

Set up your personal e-mail account such as Gmail or Yahoo! on your device.

1. On the Home screen, slide to the **Mail** tab and tap **New Account**.
2. Enter the **E-mail Address** and **Password** of your personal e-mail account and select the **Save password** checkbox. Tap **Next**.
3. After the device finds the settings for the e-mail account, tap **Next**.



Settings for the e-mail account are found in the device.

Settings for the e-mail account are NOT found in the device.

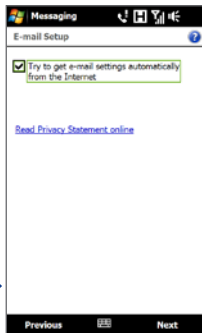

**Note** If the settings are not found in the device, the device needs to connect to the Internet to try to retrieve the settings.

4. Enter **Your name** and the **Account display name** and then tap **Next**.
 

**Note** The Account display name is the name you will see on the Mail tab of the Home screen.
5. Set how often you want your device to check for new e-mail messages in **Automatic Send/Receive** and then tap **Finish**.
6. Choose whether or not to download e-mail messages now.
7. If you have more e-mail accounts to add, tap **Menu > Accounts > New Account** on the **Mail** tab and repeat steps 2 to 6.

## To send an e-mail message

1. On the **Mail** tab of the Home screen, tap an e-mail account you want to use on the right side of the screen.
2. Tap  to create a new e-mail.
3. Enter the e-mail address of the recipient and a subject line.
4. Enter your e-mail message and then tap **Send**.

**Note** Refer to the User Manual for details on e-mail settings and features.

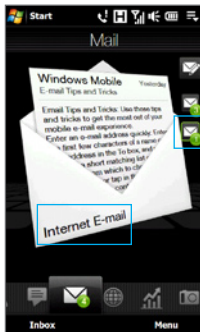

## 17. Mobile Internet

Experience desktop-like web surfing when using **Opera Mobile** to browse the Internet. You can also watch **YouTube** videos right on your device.

### Opera Mobile

1. On the Home screen, slide to the **Internet** tab and then tap **Browser** to launch Opera Mobile.
2. Tap the address bar, enter the desired web site address, and then tap .
3. To zoom in on a web page, double-tap the screen.

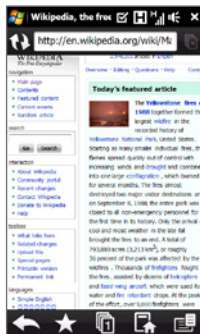

## YouTube™

With the YouTube application, you can search, view, and bookmark YouTube videos.

### To launch YouTube

Tap **Start** > **Programs** > **YouTube**.

For more information about using Opera Mobile and YouTube, refer to the “Internet” chapter on the User Manual PDF.



## 18. Bluetooth

Connect your device with a Bluetooth stereo headset or other Bluetooth-enabled devices.

### To connect your device with a Bluetooth stereo headset

1. Make sure that both your device and the Bluetooth stereo headset are turned on and within close range, and that the headset is visible. Refer to the manufacturer’s documentation to find out how to set the headset in visible mode.
2. On the Home screen, slide to the **Settings** tab and then tap **Menu** > **Bluetooth Devices** > **Devices** tab > **Add new device**.
3. Tap the name of the Bluetooth stereo headset, then tap **Next**. Your device then automatically connects with the headset.

Windows Mobile will automatically try one of the preconfigured passcodes (0000, 8888) to connect the Bluetooth headset with your device. If this fails, you have to manually enter the passcode that came with your headset.

### To connect your device with other Bluetooth devices

1. On the Home screen, slide to the **Settings** tab and then tap **Menu > Bluetooth Devices > Devices** tab.
2. Tap **Add new device**. Your device then displays the names of other Bluetooth devices within range.
3. Tap the device name in the box, then tap **Next**.
4. Specify a passcode to establish a secure connection. The passcode can be 1 up to 16 characters. Tap **Next**.
5. Wait for the paired device to accept the partnership. The receiving party needs to enter the same passcode that you specified.
6. The name of the paired device is then displayed. You may edit and enter a new name for that device.
7. Select the check boxes of services that you want to use from the paired device, and then tap **Finish**.

For more information about using Bluetooth, refer to the “Bluetooth” chapter in the User Manual PDF.

---

## 19. Keeping Track of Appointments

Use **Calendar** to help remind you of your upcoming appointments.

### To enter an appointment into your device

1. On the Home screen, select the **Home** tab and then tap **Calendar**.
2. On the Calendar screen, tap **Menu** > **New Appointment**.
3. Use the onscreen keyboard to enter the appointment details.
4. After entering the appointment details, tap **OK**.

The upcoming appointment will show on the **Home** tab of the Home screen.

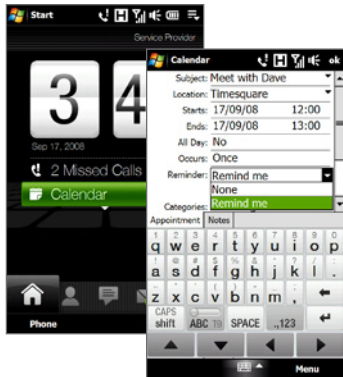

## 20. Keeping Track of Things to Do

Use **Tasks** to help you remember things that you have to do.

### To create a to-do list

1. Tap **Start** > **Programs** > **Tasks**.
2. On the Tasks screen, tap **Tap here to add a new task** and then enter the task name.
3. Tap the ENTER button on the onscreen keyboard.

**Tip** You can also tap outside the field to enter the task.

Refer to Chapter 12 of the User Manual to learn more about the advanced features of Tasks.

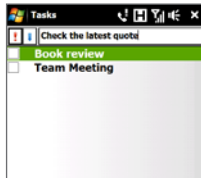

## 21. Taking Photos and Shooting Videos

Use the built-in 5.0 megapixel camera to take photos and shoot videos.

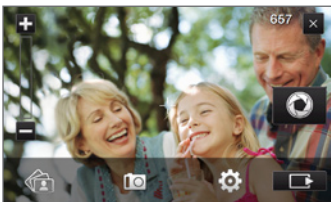

### To take a photo

1. On the Home screen, slide to the **Photos and Videos** tab and then tap the camera icon (📷). The screen orientation automatically switches to landscape mode when you open the Camera program.
2. Aim the device at the subject.
3. Touch the Virtual Camera button (📷) to activate auto-focus. When focus is set, the camera automatically takes the shot.

### To shoot video

1. On the Home screen, slide to the **Photos and Videos** tab and then tap the video icon (📹). The screen orientation automatically switches to landscape mode when you open the Camera program.
2. Aim the device at the subject.
3. Touch the Virtual Camera button (📷) to activate auto-focus. When focus is set, the camera automatically starts capturing video. To stop capturing video, touch the Virtual Camera button again.

To learn more about the other capture modes and functions of the Camera, refer to the “Experiencing Multimedia” chapter in the User Manual PDF.

## 22. Viewing Photo and Videos

After capturing photos and video clips with the camera, you can visually browse through them on the **Photos and Videos** tab of the Home screen and view them in full screen.

### Browse through photos and videos

1. On the Home screen, slide to the **Photos and Videos** tab.
2. Flip through your photos and videos by swiping your finger upward or downward on the center screen.
3. Tap a photo or video to view it in full-screen mode.

### When viewing photos in full screen

Use finger gestures to go to the next/previous image or to zoom in/out.

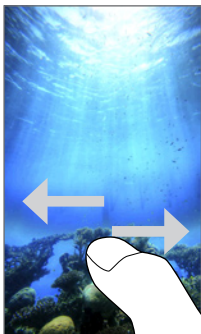

Go to next or previous image.

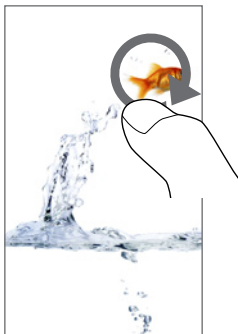

Slide your finger clockwise on an area to zoom in on that area.

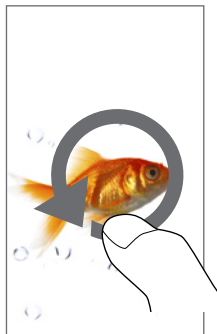

Slide your finger counter-clockwise to zoom out.

### When playing video

You can also use the Album program to view photos and videos. To launch this program, tap **Start > Programs > Album**, or tap **Album** at the bottom-left side of the screen when the **Photos and Videos** tab is displayed. For information about using Album, refer to the “Experiencing Multimedia” chapter in the User Manual PDF.

## 23. When Connecting Your Device to a Computer

Whenever you connect your device to the computer with the USB cable, the Connect to PC screen will be displayed and will prompt you to choose the type of USB connection:

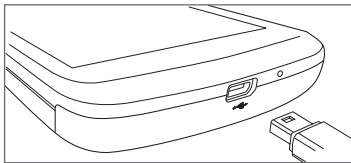

### ActiveSync

Select this mode when you need to do synchronize information and files between your device and your computer.

### Disk Drive

This mode is available for selection only when there is a microSD storage card installed on your device. Select this mode when you want to copy files between your device's storage card and your computer faster.

### Internet Sharing

When you do not have Internet access on your notebook or desktop computer, you can select this mode to use your device as a modem for your computer. For more information about using Internet Sharing, see the "Internet" chapter in the User Manual PDF.

---

---

## 24. Synchronizing Your Device with Your Computer

Synchronize information and files between your computer and device.

**Note** Refer to the “Synchronizing Information With Your Computer” chapter in the User Manual PDF to know which types of information can be synchronized between your device and a computer.

### Set up synchronization software on your computer

Depending on the Operating System of your computer, you will need either Microsoft ActiveSync® 4.5 (or later) or Windows Mobile® Device Center to synchronize your device with your computer.

#### To synchronize your device with a Windows XP computer

1. Install ActiveSync 4.5 on your computer from the Getting Started Disc.
2. Connect your device to your computer using the supplied USB cable. The Synchronization Setup Wizard automatically starts and guides you to create a synchronization partnership. Click **Next**.
3. Clear the **Synchronize directly with a server running Microsoft Exchange** check box and then click **Next**.
4. Select the information you want to synchronize and then click **Next**.
5. Select whether or not to allow wireless data connections on your device while it is connected to the computer. Click **Next**.
6. Click **Finish**.

#### To synchronize your device with a Windows Vista computer

1. Connect your device to your computer using the supplied USB cable. Windows Mobile Device Center will open. On the screen, click **Set up your device**.
2. Select the information you want to synchronize and click **Next**.
3. Enter the name for your device and then click **Set Up**.

For more information about synchronization, refer to the “Synchronizing Information With Your Computer” chapter in the User Manual PDF.

---

---

## 25. Copying Files to Your Device

You can install a microSD™ card into your device to have additional storage for storing files.

### To copy files from the computer to the device's storage card

1. Connect your device to your computer using the supplied USB cable.
2. Click **File Management > Browse the contents of your device** in Windows Mobile Device Center or click **Explore** in ActiveSync on your computer. This opens Windows Explorer on your computer and displays the contents of your device.
3. Browse the folders on your computer, right-click the file you want to copy and then click **Copy**.
4. Go to **My Windows-Based Mobile Device > Storage Card**, right-click on the screen and click **Paste**.

If you want to copy media files such as music and videos from your computer to your device, it is recommended that you use Windows Media Player to synchronize the media files. See the next section in this Quick Start Guide for instructions on how to synchronize music files to your device.

## 26. Synchronizing Music Files

Synchronize music files from your computer to your device so you can listen to them while on the go.

1. On your computer, open Windows Media® Player and then connect your device to your computer.
2. On the **Device Setup** dialog box, enter a name for your device and click **Finish**.
3. On the left panel of Windows Media® Player, right-click the name of your device and click **Set Up Sync**.

**Note** You can also sync your storage card if you have one installed on your device. To sync, right-click **Storage Card**.

---

4. Select the music playlist(s) that you want to sync between your computer and your device and then click **Add**.
5. Click **Finish**.

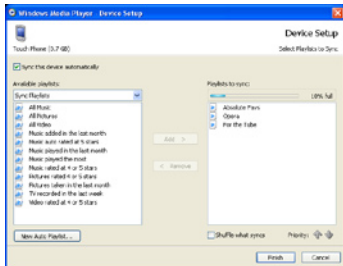

## 27. Listening to Music on Your Device

After synchronizing music files to your device, you can use the **Music** tab on the Home screen to play back music on your device.

### To listen to music

1. On the Home screen, slide to the **Music** tab.
2. Browse through albums and songs by swiping up or down on the screen, and then touch  to start playing back the displayed song.

For more information about using the Music tab, refer to the "TouchFLO 3D" chapter in the User Manual PDF.

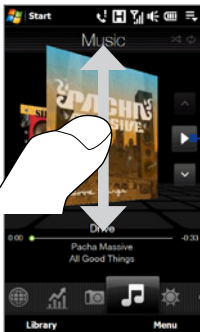

Tap to play the selected album or song.

---

## 28. Resetting Your Device

If you experience some sluggishness with your device, you can perform a reset to shut down all programs and restart your device.

### To perform a soft reset

1. Pull out the stylus.
2. Remove the back cover.
3. Use the stylus to press the RESET button located between the SIM card and storage card slots. Your device restarts and displays the Home screen.

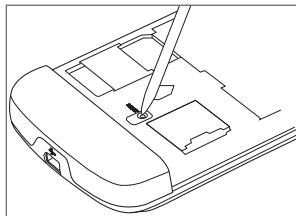

You can also perform a hard reset. **After a hard reset, the device is restored to its default settings—the way it was when you first purchased your device and turned it on.** Only Windows Mobile® software and other pre-installed programs will remain after a hard reset.

To learn how to perform a hard reset, refer to the “Managing Your Device” chapter in the User Manual PDF.

---

---

## Important Health Information and Safety Precautions

When using this product, the safety precautions below must be taken to avoid possible legal liabilities and damages.

Retain and follow all product safety and operating instructions. Observe all warnings in the operating instructions on the product.

To reduce the risk of bodily injury, electric shock, fire, and damage to the equipment, observe the following precautions.

### **ELECTRICAL SAFETY**

This product is intended for use when supplied with power from the designated battery or power supply unit. Other usage may be dangerous and will invalidate any approval given to this product.

### **SAFETY PRECAUTIONS FOR PROPER GROUNDING INSTALLATION**

**CAUTION:** Connecting to an improperly grounded equipment can result in an electric shock to your device.

This product is equipped with a USB Cable for connecting with desktop or notebook computer. Be sure your computer is properly grounded (earthed) before connecting this product to the computer. The power supply cord of a desktop or notebook computer has an equipment-grounding conductor and a grounding plug. The plug must be plugged into an appropriate outlet which is properly installed and grounded in accordance with all local codes and ordinances.

### **SAFETY PRECAUTIONS FOR POWER SUPPLY UNIT**

- **Use the correct external power source**

A product should be operated only from the type of power source indicated on the electrical ratings label. If you are not sure of the type of power source required, consult your authorized service provider or local power company. For a product that operates from battery power or other sources, refer to the operating instructions that are included with the product.

---

---

- **Handle battery packs carefully**

This product contains a Li-ion or Li-ion Polymer battery. There is a risk of fire and burns if the battery pack is handled improperly. Do not attempt to open or service the battery pack. Do not disassemble, crush, puncture, short external contacts or circuits, dispose of in fire or water, or expose a battery pack to temperatures higher than 60°C (140°F).



**WARNING:** Danger of explosion if battery is incorrectly replaced. To reduce risk of fire or burns, do not disassemble, crush, puncture, short external contacts, expose to temperature above 60° C (140° F), or dispose of in fire or water. Replace only with specified batteries. Recycle or dispose of used batteries according to the local regulations or reference guide supplied with your product.



- **Take extra precautions**

- Keep the battery or device dry and away from water or any liquid as it may cause a short circuit.
  - Keep metal objects away so they don't come in contact with the battery or its connectors as it may lead to short circuit during operation.
  - Do not use a battery that appears damaged, deformed, or discolored, or the one that has any rust on its casing, overheats, or emits a foul odor.
  - Always keep the battery out of the reach of babies and small children, to avoid swallowing of the battery. Consult the doctor immediately if the battery is swallowed.
  - If the battery leaks:
    - Do not allow the leaking fluid to come in contact with skin or clothing. If already in contact, flush the affected area immediately with clean water and seek medical advice.
-

- 
- Do not allow the leaking fluid to come in contact with eyes. If already in contact, DO NOT rub; rinse with clean water immediately and seek medical advice.
  - Take extra precautions to keep a leaking battery away from fire as there is a danger of ignition or explosion.

### **SAFETY PRECAUTIONS FOR DIRECT SUNLIGHT**

Keep this product away from excessive moisture and extreme temperatures. Do not leave the product or its battery inside a vehicle or in places where the temperature may exceed 60°C (140°F), such as on a car dashboard, window sill, or behind a glass that is exposed to direct sunlight or strong ultraviolet light for extended periods of time. This may damage the product, overheat the battery, or pose a risk to the vehicle.

### **PREVENTION OF HEARING LOSS**



**CAUTION:** Permanent hearing loss may occur if earphones or headphones are used at high volume for prolonged periods of time.

**NOTE:** For France, Earphone (listed below) for this device have been tested to comply with the Sound Pressure Level requirement laid down in the applicable NF EN 50332-1:2000 and/or NF EN 50332-2:2003 standards as required by French Article L. 5232-1.

- Earphone, manufactured by HTC, Model HS G335.

### **SAFETY IN AIRCRAFT**

Due to the possible interference caused by this product to an aircraft's navigation system and its communications network, using this device's phone function on board an airplane is against the law in most countries. If you want to use this device when on board an aircraft, remember to turn off your phone by switching to Airplane Mode.

### **ENVIRONMENT RESTRICTIONS**

Do not use this product in gas stations, fuel depots, chemical plants or where blasting operations are in progress, or in potentially explosive atmospheres such as fuelling areas, fuel storehouses, below deck on boats, chemical plants, fuel or chemical transfer or storage facilities, and areas where the air contains chemicals or particles, such as grain,

---

---

dust, or metal powders. Please be aware that sparks in such areas could cause an explosion or fire resulting in bodily injury or even death.

### **EXPLOSIVE ATMOSPHERES**

When in any area with a potentially explosive atmosphere or where flammable materials exist, the product should be turned off and the user should obey all signs and instructions. Sparks in such areas could cause an explosion or fire resulting in bodily injury or even death. Users are advised not to use the equipment at refueling points such as service or gas stations, and are reminded of the need to observe restrictions on the use of radio equipment in fuel depots, chemical plants, or where blasting operations are in progress. Areas with a potentially explosive atmosphere are often, but not always, clearly marked. These include fueling areas, below deck on boats, fuel or chemical transfer or storage facilities, and areas where the air contains chemicals or particles, such as grain, dust, or metal powders.

### **ROAD SAFETY**

Vehicle drivers in motion are not permitted to use telephony services with handheld devices, except in the case of emergency. In some countries, using hands-free devices as an alternative is allowed.

### **SAFETY PRECAUTIONS FOR RF EXPOSURE**

- Avoid using your phone near metal structures (for example, the steel frame of a building).
- Avoid using your phone near strong electromagnetic sources, such as microwave ovens, sound speakers, TV and radio.
- Use only original manufacturer-approved accessories, or accessories that do not contain any metal.
- Use of non-original manufacturer-approved accessories may violate your local RF exposure guidelines and should be avoided.

### **INTERFERENCE WITH MEDICAL EQUIPMENT FUNCTIONS**

This product may cause medical equipment to malfunction. The use of this device is forbidden in most hospitals and medical clinics.

---

---

If you use any other personal medical device, consult the manufacturer of your device to determine if they are adequately shielded from external RF energy. Your physician may be able to assist you in obtaining this information.

Turn your phone OFF in health care facilities when any regulations posted in these areas instruct you to do so. Hospitals or health care facilities may be using equipment that could be sensitive to external RF energy.

## HEARING AIDS

Some digital wireless phones may interfere with some hearing aids. In the event of such interference, you may want to consult your service provider, or call the customer service line to discuss alternatives.

## NONIONIZING RADIATION

Your device has an internal antenna. This product should be operated in its normal-use position to ensure the radiative performance and safety of the interference. As with other mobile radio transmitting equipment, users are advised that for satisfactory operation of the equipment and for the safety of personnel, it is recommended that no part of the human body be allowed to come too close to the antenna during operation of the equipment.

Use only the supplied integral antenna. Use of unauthorized or modified antennas may impair call quality and damage the phone, causing loss of performance and SAR levels exceeding the recommended limits as well as result in non-compliance with local regulatory requirements in your country.

To assure optimal phone performance and ensure human exposure to RF energy is within the guidelines set forth in the relevant standards, always use your device only in its normal-use position. Contact with the antenna area may impair call quality and cause your device to operate at a higher power level than needed.



---

Avoiding contact with the antenna area when the phone is IN USE optimizes the antenna performance and the battery life.

## General Precautions

- **Avoid applying excessive pressure to the device**

Do not apply excessive pressure on the screen and the device to prevent damaging them and remove the device from your pants' pocket before sitting down. It is also recommended that you store the device in a protective case and only use the device stylus or your finger when interacting with the touch screen. Cracked display screens due to improper handling are not covered by the warranty.

- **Device getting warm after prolonged use**

When using your device for prolonged periods of time, such as when you're talking on the phone, charging the battery or browsing the web, the device may become warm. In most cases, this condition is normal and therefore should not be interpreted as a problem with the device.

- **Heed service markings**

Except as explained elsewhere in the Operating or Service documentation, do not service any product yourself. Service needed on components inside the device should be done by an authorized service technician or provider.

- **Damage requiring service**

Unplug the product from the electrical outlet and refer servicing to an authorized service technician or provider under the following conditions:

- Liquid has been spilled or an object has fallen onto the product.
- The product has been exposed to rain or water.
- The product has been dropped or damaged.
- There are noticeable signs of overheating.
- The product does not operate normally when you follow the operating instructions.

- **Avoid hot areas**

The product should be placed away from heat sources such as radiators, heat registers, stoves, or other products (including amplifiers) that produce heat.

---

---

- **Avoid wet areas**

Never use the product in a wet location.

- **Avoid using your device after a dramatic change in temperature**

When you move your device between environments with very different temperature and/or humidity ranges, condensation may form on or within the device. To avoid damaging the device, allow sufficient time for the moisture to evaporate before using the device.

**NOTICE:** When taking the device from low-temperature conditions into a warmer environment or from high-temperature conditions into a cooler environment, allow the device to acclimate to room temperature before turning on power.

- **Avoid pushing objects into product**

Never push objects of any kind into cabinet slots or other openings in the product. Slots and openings are provided for ventilation. These openings must not be blocked or covered.

- **Mounting accessories**

Do not use the product on an unstable table, cart, stand, tripod, or bracket. Any mounting of the product should follow the manufacturer's instructions, and should use a mounting accessory recommended by the manufacturer.

- **Avoid unstable mounting**

Do not place the product with an unstable base.

- **Use product with approved equipment**

This product should be used only with personal computers and options identified as suitable for use with your equipment.

- **Adjust the volume**

Turn down the volume before using headphones or other audio devices.

- **Cleaning**

Unplug the product from the wall outlet before cleaning. Do not use liquid cleaners or aerosol cleaners. Use a damp cloth for cleaning, but NEVER use water to clean the LCD screen.

---

---

## Regulatory Agency Identifications

For regulatory identification purposes, your product is assigned a model number of **BLAC100**.

To ensure continued reliable and safe operation of your device, use only the accessories listed below with your **BLAC100**.

The Battery Pack has been assigned a model number of **BLAC160**.

**Note** This product is intended for use with a certified Class 2 Limited Power Source, rated 5 Volts DC, maximum 1 Amp power supply unit.

## Telecommunications & Internet Association (TIA)

### Safety Information

#### Pacemakers

The Health Industry Manufacturers Association recommends that a minimum separation of six inches be maintained between a handheld wireless phone and a pacemaker to avoid potential interference with the pacemaker. These recommendations are consistent with the independent research by and recommendations of Wireless Technology Research.

Persons with pacemakers:

- Should ALWAYS keep the phone more than six inches from their pacemaker when the phone is turned ON.
- Should not carry the phone in a breast pocket.
- Should use the ear opposite the pacemaker to minimize the potential for interference. If you have any reason to suspect that interference is taking place, turn the phone OFF immediately.

#### Hearing Aids

Some digital wireless phones may interfere with some hearing aids. In the event of such interference, you may want to consult your service provider, or call the customer service line to discuss alternatives.

#### Other Medical Devices

If you use any other personal medical device, consult the manufacturer of your device to determine if they are adequately shielded from external RF energy. Your physician may be able to assist you in obtaining this information.

---

---

Turn the phone OFF in health care facilities when any regulations posted in these areas instruct you to do so. Hospitals or health care facilities may be using equipment that could be sensitive to external RF energy.

## WEEE Notice

The Directive on Waste Electrical and Electronic Equipment (WEEE), which entered into force as European law on 13th February 2003, resulted in a major change in the treatment of electrical equipment at end-of-life.

The purpose of this Directive is, as a first priority, the prevention of WEEE, and in addition, to promote the reuse, recycling and other forms of recovery of such wastes so as to reduce disposal.



The WEEE logo (shown at the left) on the product or on its box indicates that this product must not be disposed of or dumped with your other household waste. You are liable to dispose of all your electronic or electrical waste equipment by relocating over to the specified collection point for recycling of such hazardous waste. Isolated collection and proper recovery of your electronic and electrical waste equipment at the time of disposal will allow us to help conserving natural resources. Moreover, proper recycling of the electronic and electrical waste equipment will ensure safety of human health and environment. For more information about electronic and electrical waste equipment disposal, recovery, and collection points, please contact your local city center, household waste disposal service, shop from where you purchased the equipment, or manufacturer of the equipment.

## RoHS Compliance

This product is in compliance with Directive 2002/95/EC of the European Parliament and of the Council of 27 January 2003, on the restriction of the use of certain hazardous substances in electrical and electronic equipment (RoHS) and its amendments.

---

---

---